

Monday, 30.June 2008

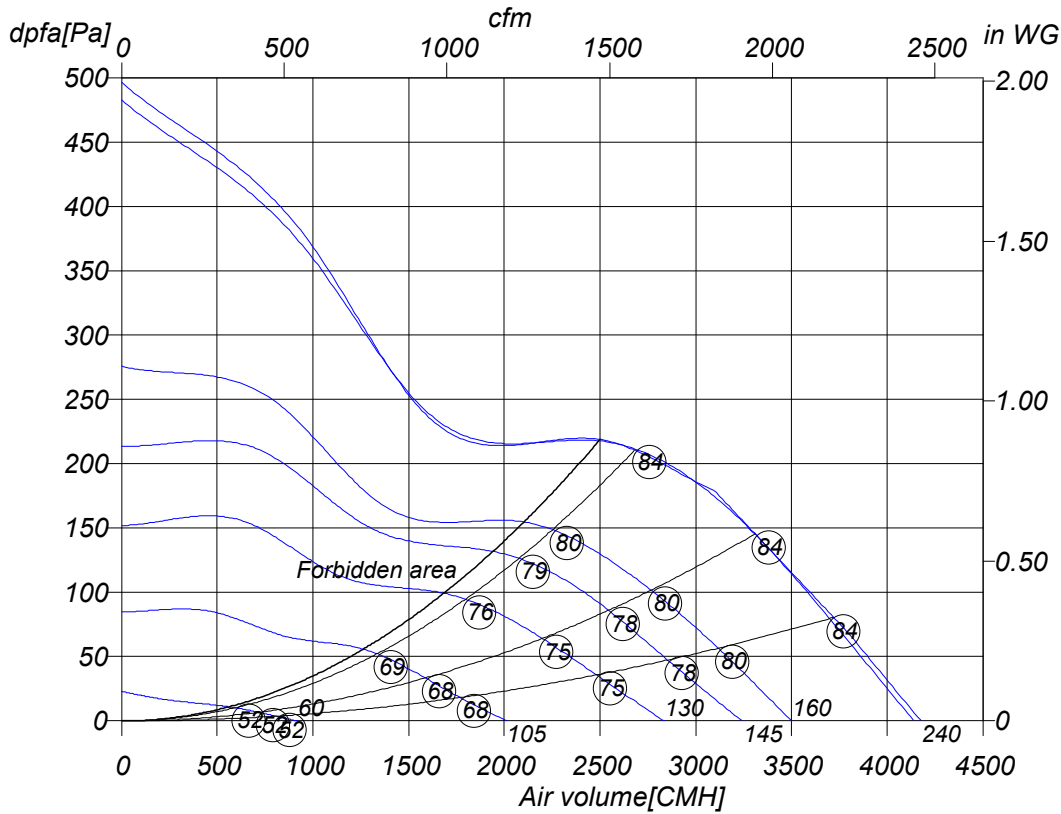

### Axial fan



<b>ER 315-2</b>	
Art. No.	E10-31510
U[V]	230
f[Hz]	50
P[kW]	0.69
I[A]	3.0
n[1/min]	2610
C[μF]	14
tR[°C]	50
dpst[Pa]	-
Delta I[%]	27
Ia/In	2.4
IP	54
Weight[kG]	9
Wir. diagr.	01.025

○ Sound power level  
 LwA6[dBA]

#### Octave sound power level

f[Hz]	125	250	500	1000	2000	4000	8000
LwA6[dBA]:	-25	-14	-7	-4	-4	-7	-16



Monday, 30.June 2008



**Axial fan**

**ER 315-2**

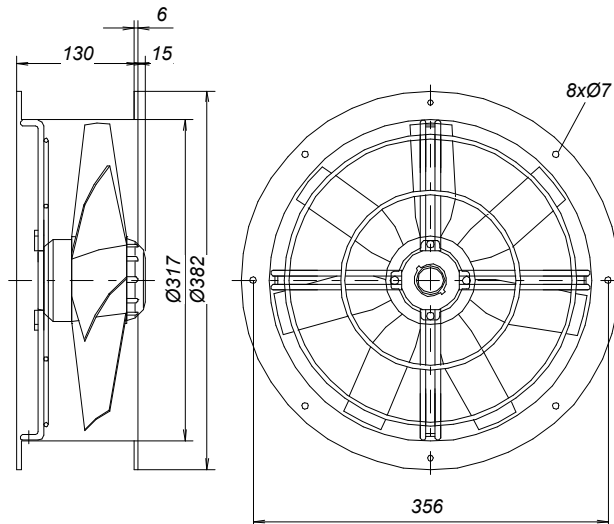

Monday, 30.June 2008

Pos.	Pieces	Description	Price
		<p><i>Rosenberg high efficiency axial fans in low pressure execution</i></p> <p><i>Casing made from galvanized and plastic-coated steel, EQ/DQ series plate mounted, ER/DR series short cased with two flanges.</i></p> <p><i>Impellers with aerodynamically shaped blades, up to size 300 made from galvanized steel, from size 315 up to size 630-6 made from plastic, from size 630-4 from die-cast aluminium, mounted onto a speed controllable external rotor motor. The fan is balanced on two levels according to quality level G 2.5 DIN/ISO 1940.</i></p> <p><i>Closed motor, protection class IP 44/54 with protection against humidity and thermal contacts wired in windings for motor protection from size 315.</i></p> <p><i>Maintenance free ball bearings closed on both sides, sealed for life. Electrical connection through terminal box (not connected) in IP 44.</i></p> <p><i>Documentation: Manufacturers declaration and operating instruction are according to machinery directive 89/392/EEC, CE identification in accordance to EMC-directive 89/336/EEC and low voltage directive 73/23/EEC. Motor operating instruction are available from motor manufacturer.</i></p> <p><b>Nominal data</b></p> <p>Type ER 315-2</p> <p>Article no. E10-31510</p> <p>Voltage[V] 230</p> <p>Frequency[Hz] 50</p> <p>Power P1[kW] 0.69</p> <p>Current I[A] 3.0</p> <p>Speed n[1/min] 2610</p> <p>Capacitor C[μF] 14</p> <p>Max. air temp.tR[°C] 50</p> <p>Min. pressure dpst[Pa] -</p> <p>Delta I[%] 27</p> <p>Startup current Ia/In 2.4</p> <p>Protection-mode IP 54</p> <p>Weight[kg] 9</p> <p>wiring diagram 01.025</p>	

Monday, 30.June 2008



## Axial fan

### ER 315-2

Einphasenwechselstrommotor mit Betriebskondensator und Thermokontakt. Bei Verwendung von RE Steuergeräten TK mit der Wicklung in Reihe schalten. Hierfür Brücke (x) einlegen und gestrichelt gezeichnete Anschlüsse belegen.

Single phase A.C. motor with operating capacitor and thermal contact. Thermal contact wired in series with windings if RE controllers are used. Insert bridge (x) and wire connections shown as dash-line on the drawing.

*Moteur monophasé avec condensateur permanent et thermovontact branché en série avec le bobinage en cas de brachement avec des régulateurs RE. Mettre un pont (x) et brancher toutes les connexions dessinées en hachuré.*

Linkslauf  
 anti-clockwise  
 rotation anti-horaire

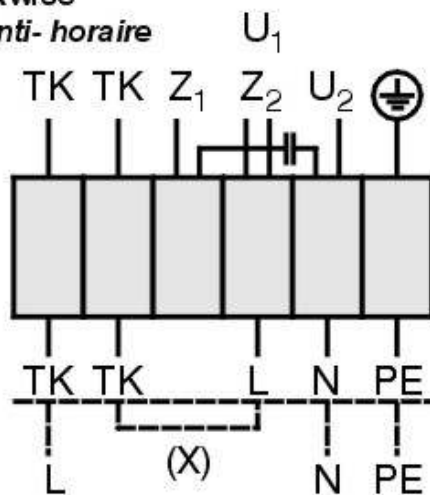

- U<sub>1</sub> braun / brown / brun
- U<sub>2</sub> blau / blue / bleu
- Z<sub>1</sub> schwarz / black / noir
- Z<sub>2</sub> orange / orange / orange
- TK weiß / white / blanc
- PE gelb-grün  
yellow-green  
jaun-vert

01.025

TK3-20003