

Installation FD-1V

Series 100 fire damper c/w HEVAC frame in masonry wall



Upon receipt of unit - Before signing for the delivery

- Fluorescent yellow stickers are attached to every package we despatch detailing receipt instructions and what to do if your goods are damaged.
- The instructions on this must be followed or HVC will not be able to assist with any claims for damage.

Prior to installation

- If damper is to be stored on site, ensure it is stored in a clean and dry environment.
- Immediately prior to fitment, remove all packaging from the unit. Take particular care inspecting the inside of the unit for any packing materials which may disrupt damper operation.

Installation

- Fire damper installation should only be carried out by competent persons. As life safety devices, correct operation is reliant on correct installation.
- Damper edges can be sharp. PPE should be used when handling.
- Larger dampers can be very heavy, ensure suitable lifting methods are used to help prevent injury.
- Adjacent dampers should be positioned not less than 200mm apart at their extremities.
- Remove the safety cable tie around the fusible link. Failure to remove this will render the damper inoperable.
- For detailed installation instructions see the following page.

Operation

- Fusible link fire dampers are designed to operate without any command from an operator or building maintenance system (unless equipped with an electromagnet or solenoid).
- Fusible links will release at the temperature embossed onto the link body.
- The use of electromagnets and solenoids enables the damper to be operated remotely, even when the damper itself is not being exposed to elevated temperatures.
- The activation command may originate from an automated command or a human operator through the building maintenance system.
- Once the damper has been shut, it can only be opened by hand.
- Once exposed to elevated temperatures/flames resulting in the damper closing, the damper must be replaced.

Spares

- A spare amount of replacement fusible links should be kept on site.

Installation FD-1V

Series 100 fire damper c/w HEVAC frame in masonry wall



BS EN 13501-3:2005 + A1:2009
 Classification report number: 301099A
 Issue 1

Installation

- Install damper centrally in the depth of the wall, the wall being not less than 150mm thick of aerated blockwork or concrete construction.
- If wall is thicker, installation so damper centre line is not less than 50mm from nearest wall face is acceptable.
- Wall aperture should be sized to give approximately 10mm clearance between damper extremities and wall.
- HEVAC frame tabs should be bent outwards and set into recesses in the wall aperture approximately 100mm long x 50mm deep in positions coinciding with the frame tab positions.
- Gaps between the HEVAC frame and the aperture should then be filled with mortar.

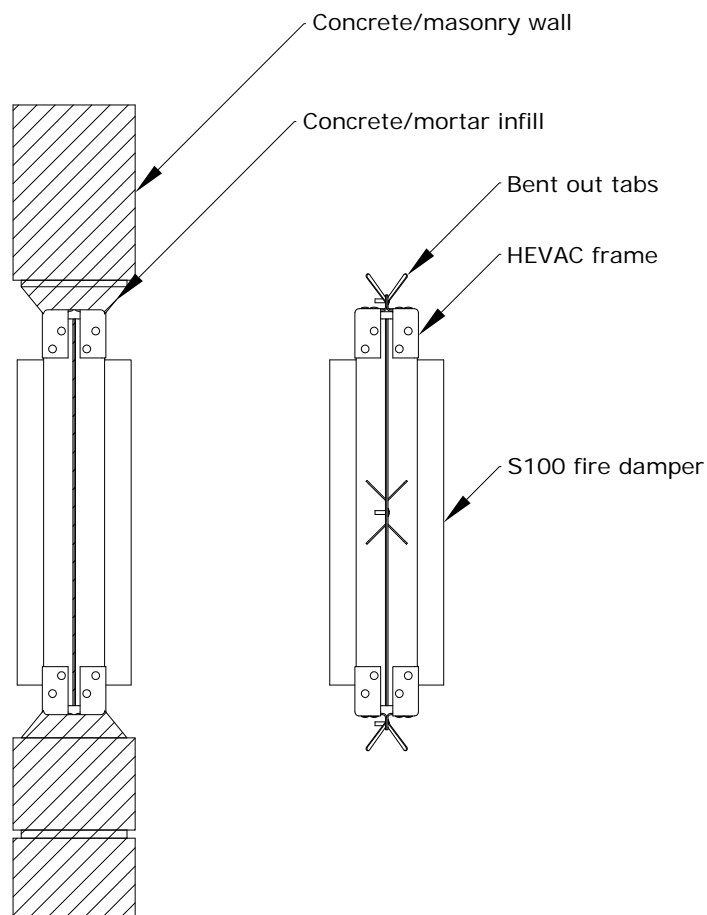
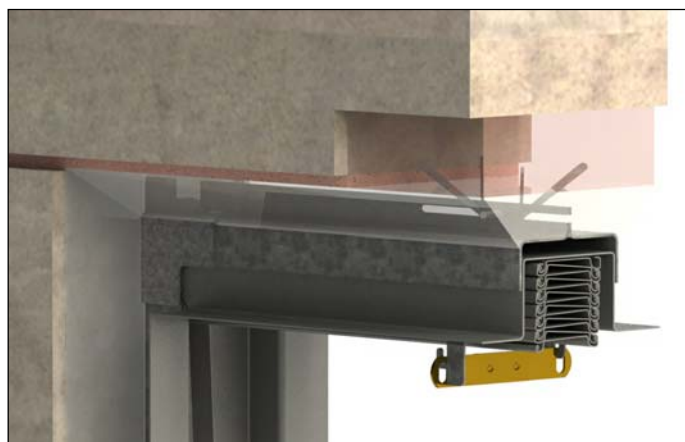
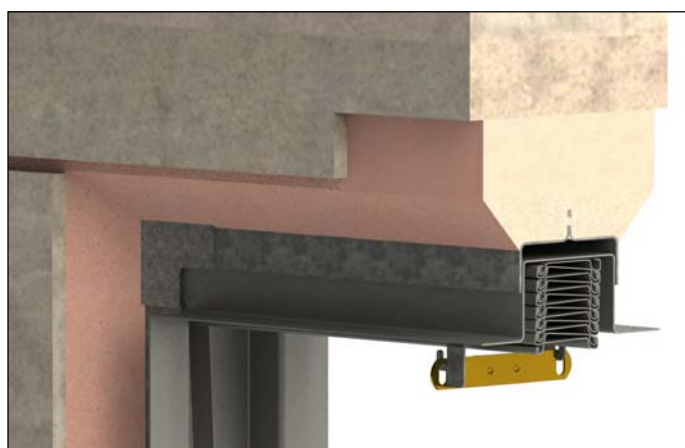

Installation Declaration for Series 100 Fire Dampers

- It is the installer's responsibility to ensure the installation is done as per the installation method provided.
- This document must be completed when installing any HVC Fire Damper.
- By signing this document you are declaring that the correct installation method has been followed.

Check:	Yes/No
Is the installed damper the correct type?	
Is the damper installed correctly?	
Has the damper been correctly identified?	
Has the correct orientation been used?	
Are there sufficient access routes installed?	
Has a check of the damper been carried out for: <ul style="list-style-type: none"> • Internal cleanliness? • Damage? • Obstructing debris? 	
Has a drop test been carried out?	
At the time of handover is the fire barrier and penetration seal complete?	

Damper unique system I.D. (If applicable):	
Damper location:	
Installation address:	
Damper type: e.g. S100BGP	
Link rated temperature:	
Notes:	

Installer's name:	
Company name:	
Company address:	
Company telephone number:	

I hereby confirm that the damper detailed above has been installed in accordance with HVC Supplies (Stourbridge) Ltd's tested installation method, and has been tested as above.

Installer's signature:

Date: