

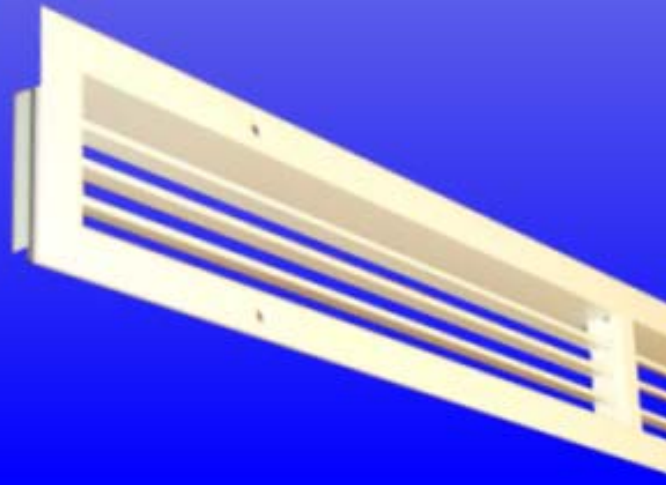

# Single deflection grille Series SD

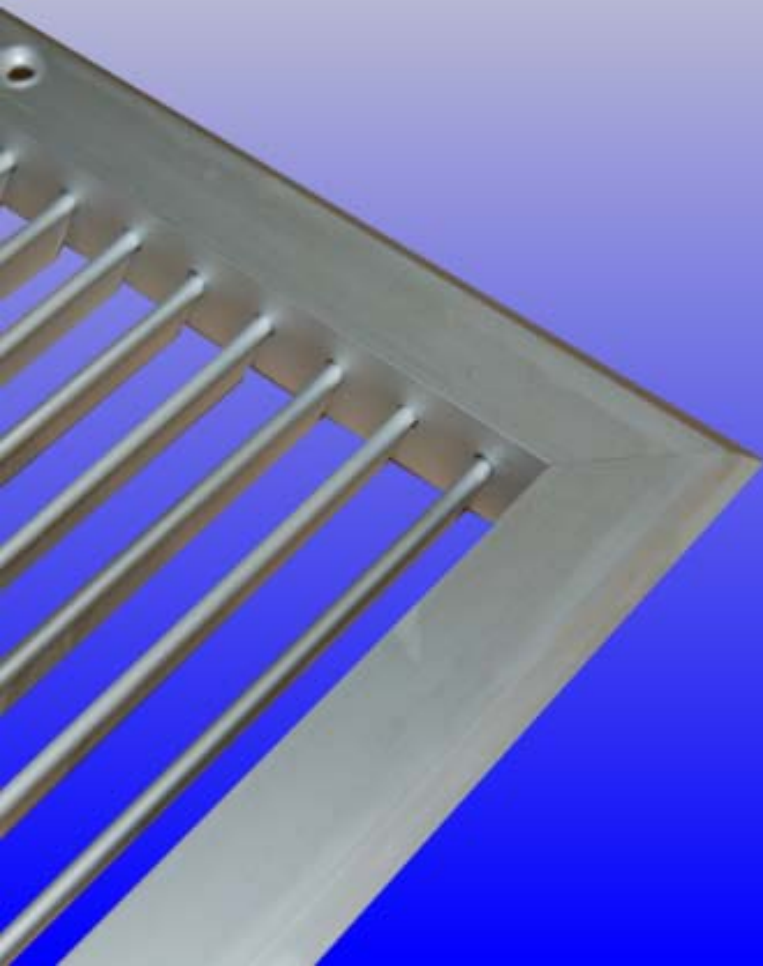

# Single Deflection Grille

## Model

SD

## Overview

Single deflection grilles are an excellent all-round air terminal. They are suitable for both supply and extract applications and enable adjustment of throw direction in a single plane.



## Construction

- Extruded aluminium frame and blades.
- One set of individually adjustable blades held in place by high tensile spring wire.
- Central mullions used on grilles with width greater than 550mm.

## Options and accessories

HVC can supply you a standard Single Deflection Grille, or a customised grille made to your exact specifications. Please see our list of options and accessories below for an overview of what we can do.

- **Opposed blade damper** - Operated via key/screwdriver through face of grille. Lever operated OBDs can also be fitted to single deflection grilles. The lever protrudes through the grille face allowing easy damper adjustment.
- **Removable or hinged core** - Making maintenance and duct access faster and easier.
- **Finishes** - HVC can polyester powder coat or nylon coat your Single Deflection Grille to any RAL or BS colour, non painted finishes are mill or satin anodised (AA5).
- **Blanking plate** - Blanking plates enable a portion or all of the grille to be disabled., and are also useful for preventing line of sight into ductwork or the ceiling void.
- **Specialised tiles** - HVC can cater for situations where specific tile formats are needed. Please get in touch with our sales team for more information on SDs fitted into tile layouts such as Burgess clip in systems.



## Blade profile

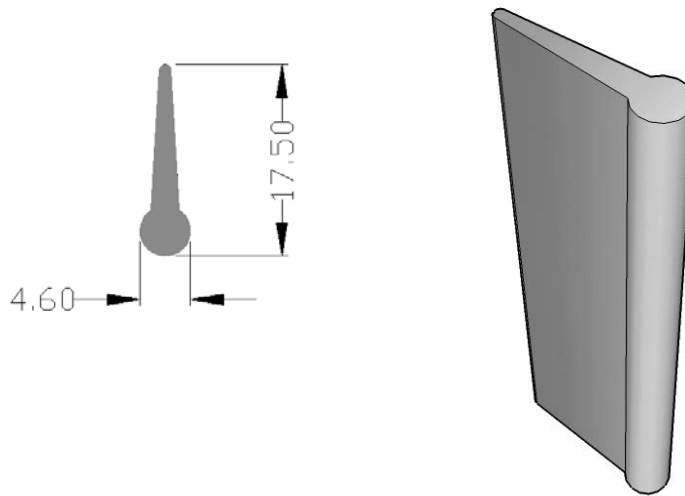

## Frame types

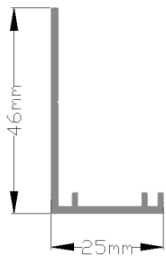

25mm flat flange

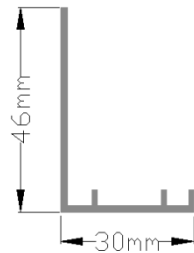

30mm flat flange

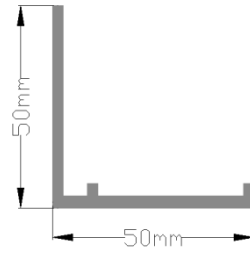

50mm flat flange

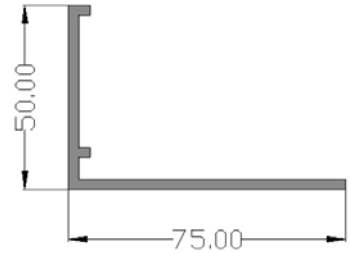

75mm flat flange

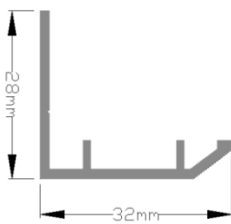

32mm bevelled small angle flange

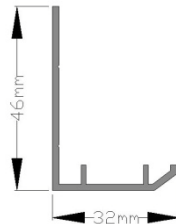

32mm bevelled large angle flange

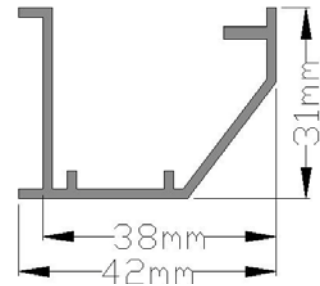

Surface mounted frame



## Technical information

- Free area – Approx 80%
- SD Mass/M<sup>2</sup> face area = 8.5KG
- SD/D Mass/M<sup>2</sup> face area = 16KG
- (\_\_\_ x \_\_\_) - SD – 32mm small angle

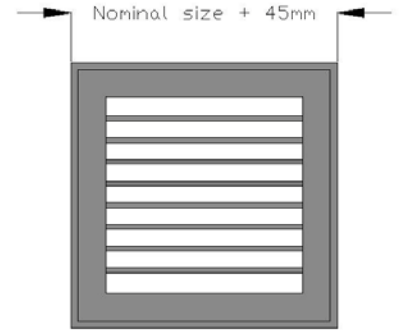
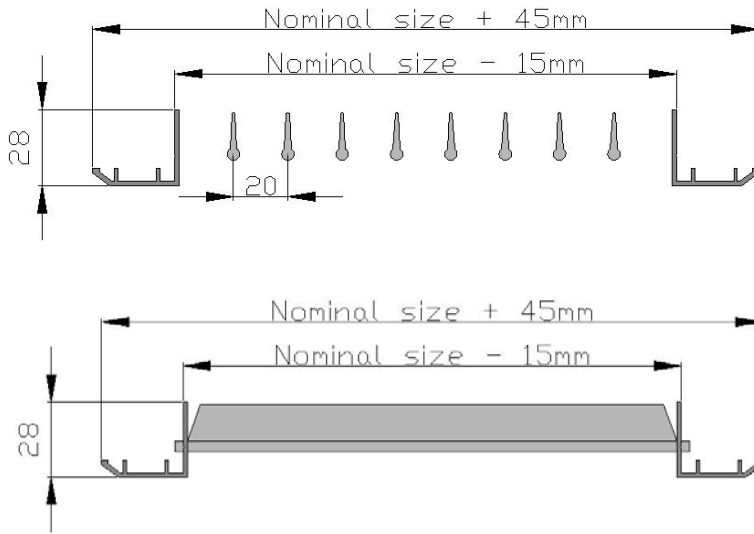

- (\_\_\_ x \_\_\_) - SD – 32mm small angle - D

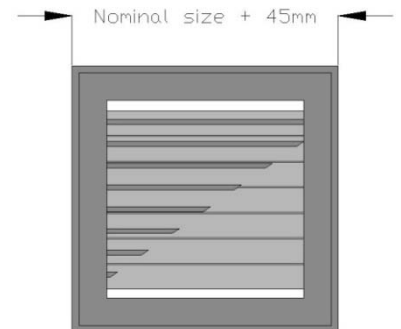
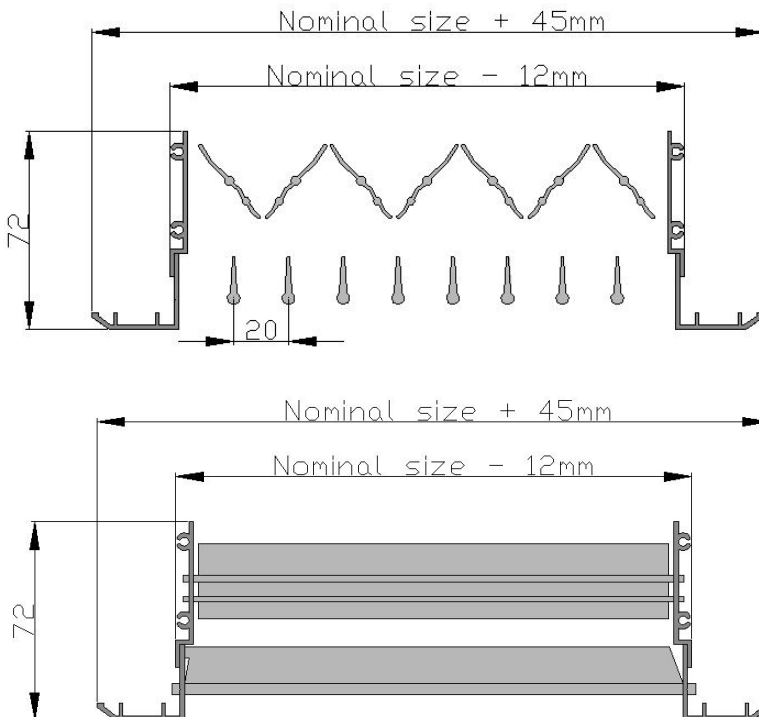

### FIXING HOLES

When using countersunk fixing holes connect the reverse of the grille to the ductwork. Then, simply fix the grille to the wall or ceiling using the supplied screws.

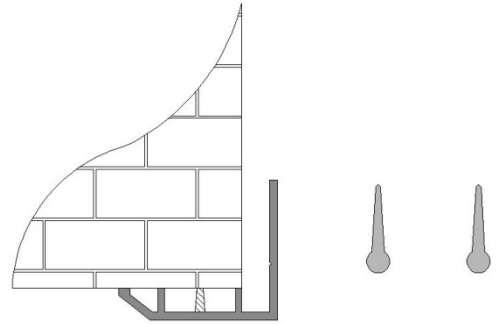

### CONCEALED FIXINGS

If using concealed fixings, fix the top 'L' bracket to the inside of the ductwork. Use the supplied bolt to then bolt the lower 'L' riveted to the grille, to the upper 'L' inside the duct.

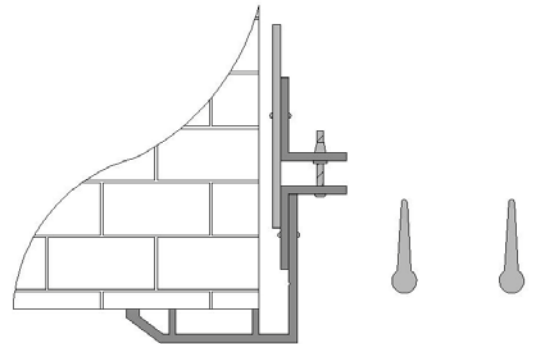

### LAY IN

Simply lay the grille into the pre-prepared T bar ceiling grid. Please note that a lay in grille would be manufactured with a 25mm flat flange as standard.

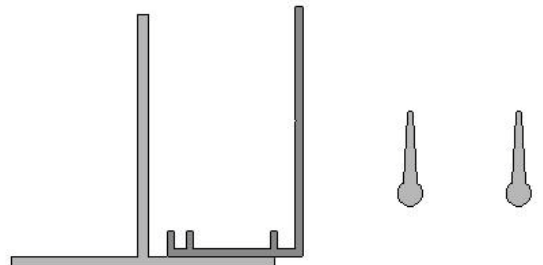

### BURGESS / OTHER TILE SYSTEM

The grille will be fitted into the tile before despatch. Installation then involves connecting the reverse of the grille to ductwork, and clipping the burgess tile into the pre-prepared ceiling grid.

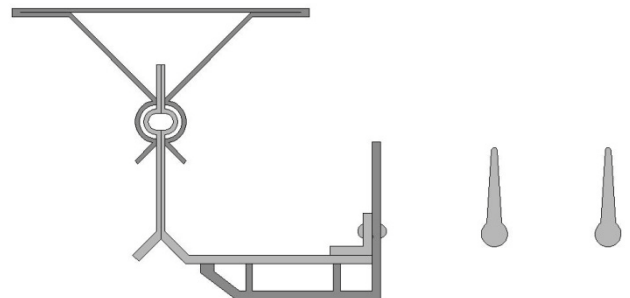

### Hinged core

Hinged cores are also available. The blades are held within the interior frame which is held into the exterior frame by a piano hinge on one side and cam fasteners (standard) or colour matched bolts (shown and optional) on the other.

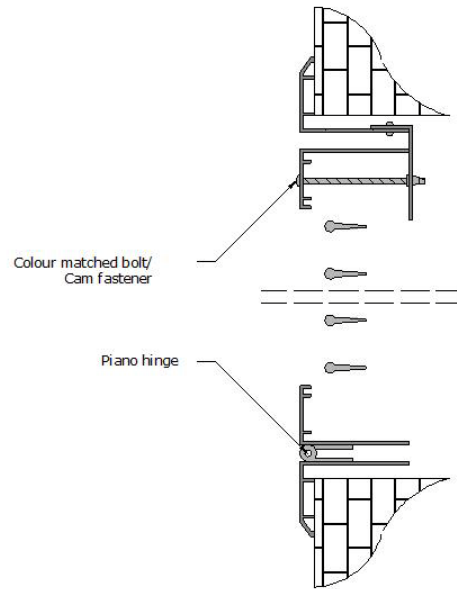

### Removable core

A single deflection grille can be manufactured with a removable core to enable complete removal from the frame. Colour matched bolts are used to hold the inner core into the frame .

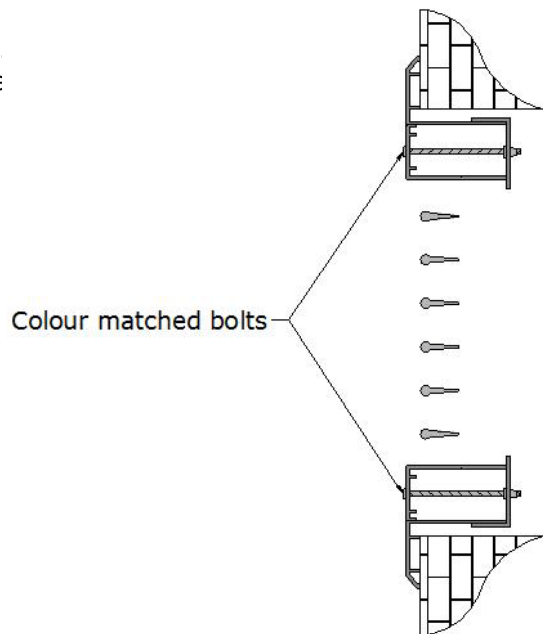

# Selection data

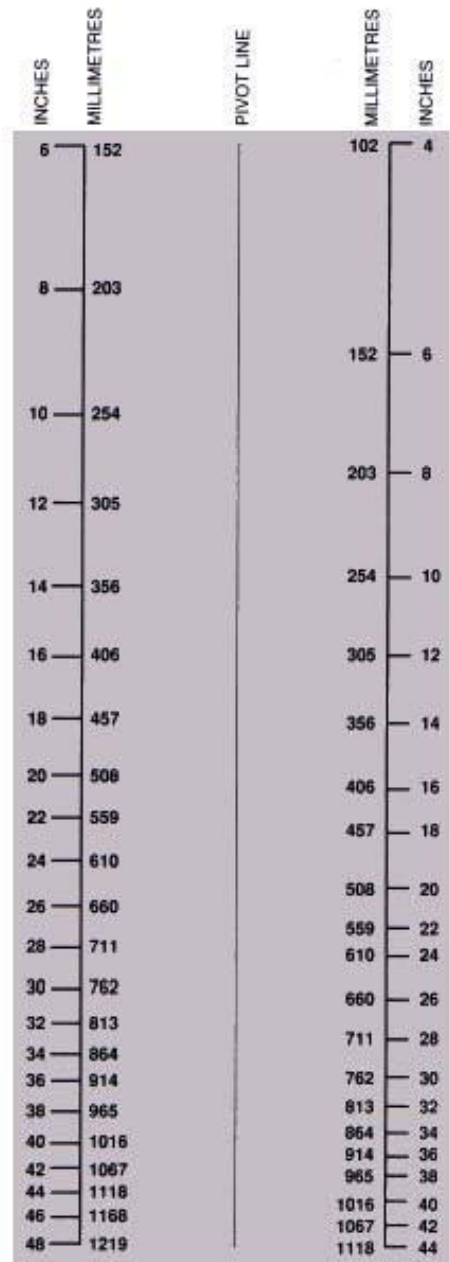
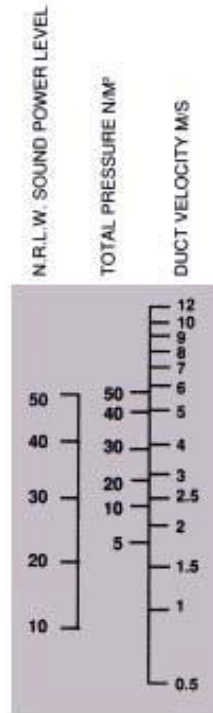
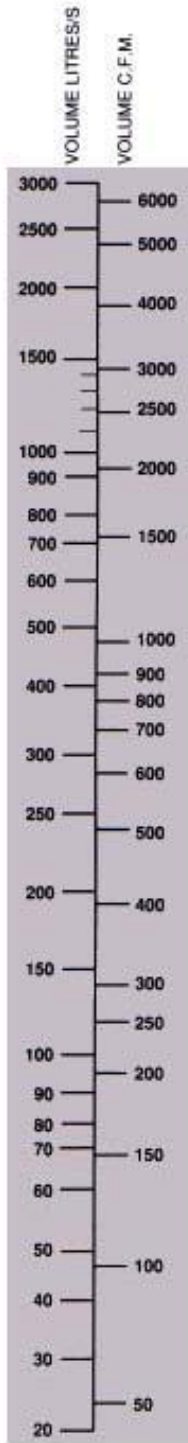

## Ordering Codes

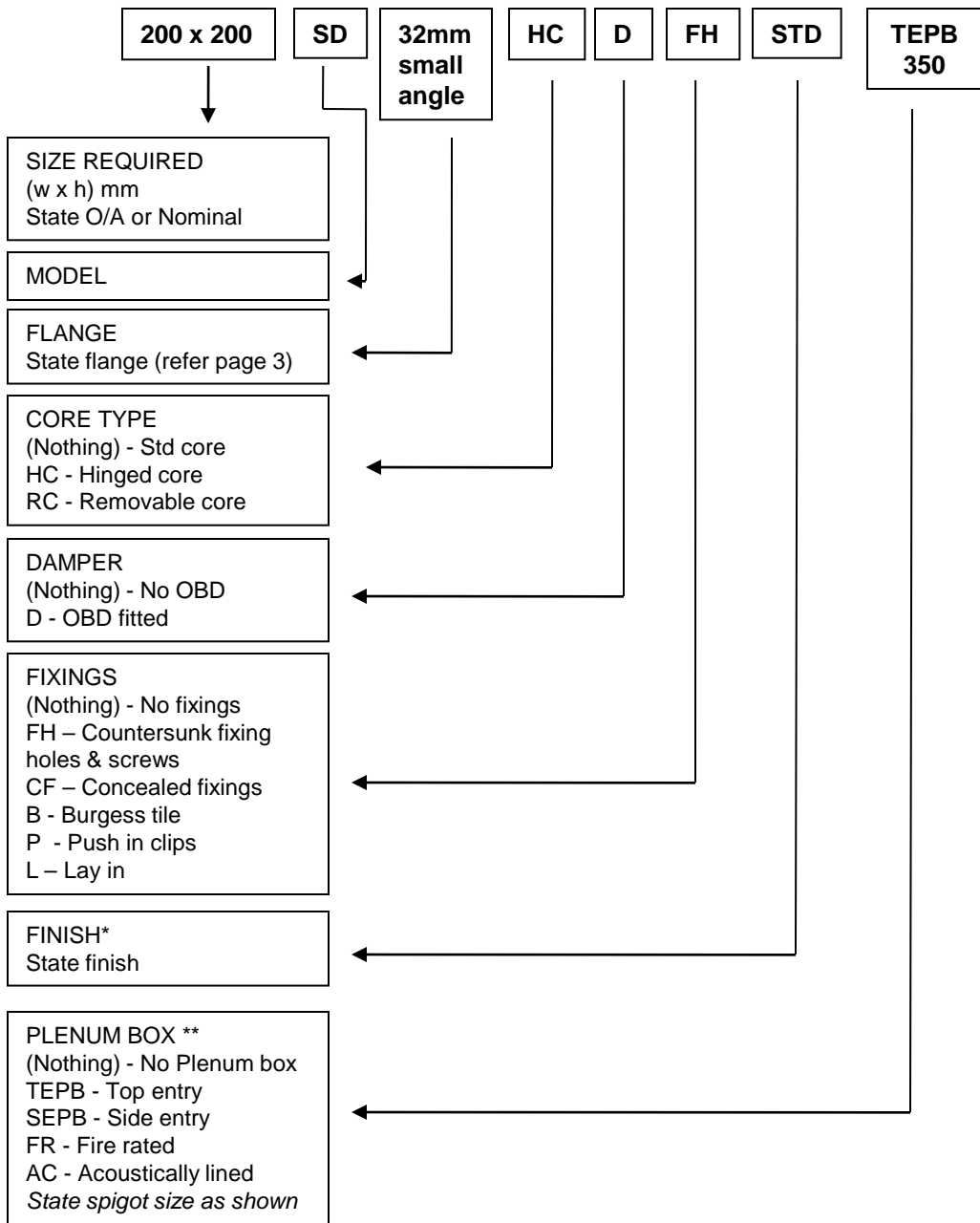

\* Standard (std) finish on SD grilles is satin anodised (AA5)

\*\* Plenum boxes are as standard 100mm deep, please state should other depth be required.

HVC Supplies (Stourbridge) Ltd reserves the right to alter, without notice, any specifications issued. Any alterations made will appear on [www.h-v-c.com](http://www.h-v-c.com) as soon as possible.

